

DEPORTED DEBOBBLED

VOL. 3 PRESENTED BY DONALD TRUMP

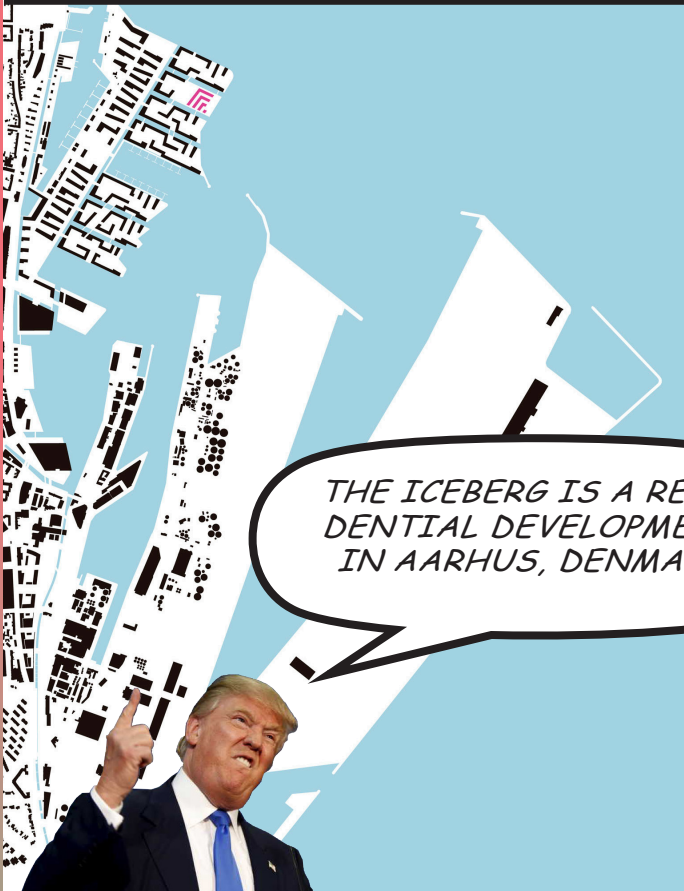

... WHEN DONALD TRUMP GOT WIND OF AN ADVANCED DESIGN 2 PAPER ENTITLED: DEPORTED, NATURALLY HE WAS INTRIGUED. BEING AN ARDENT SUPPORTER OF DEPORTATION, HE SIGNED ON AND STRUCK A TELLING BLOW TO MEXICAN METEOROLOGY, SENDING YANET GARCIA'S ASS BACK TO MONTERREY ...



THE ICEBERG IS A RESIDENTIAL DEVELOPMENT IN AARHUS, DENMARK

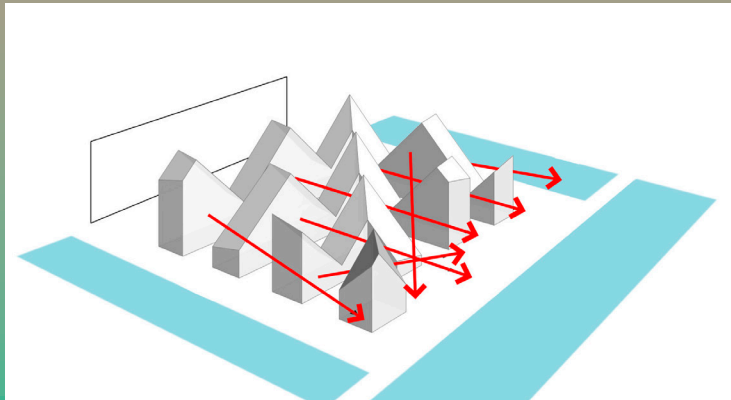
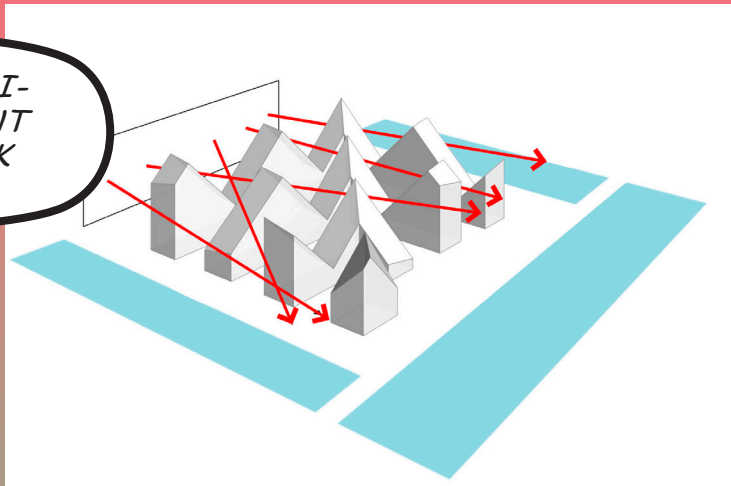
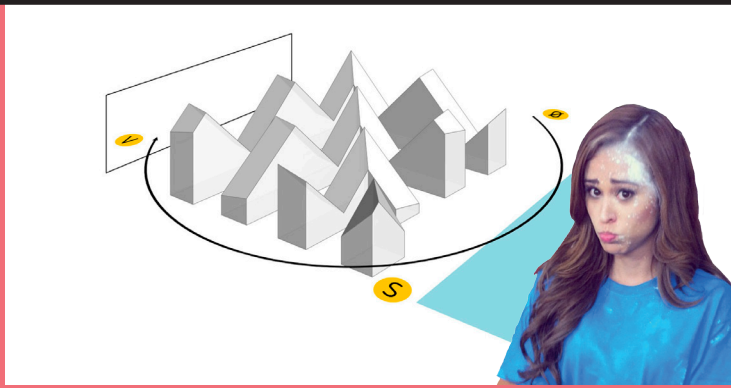

... TO MAXIMIZE VIEWS OF THE HARBOUR AND DAYLIGHT TO 7000 INHABITANTS, AND RESPECTING THE INLAND URBAN CONTEXT, THE BUILDING FORMS PEAKS AND VALLEYS CREATING VISUAL PATHWAYS THROUGH THE BUILDING ...

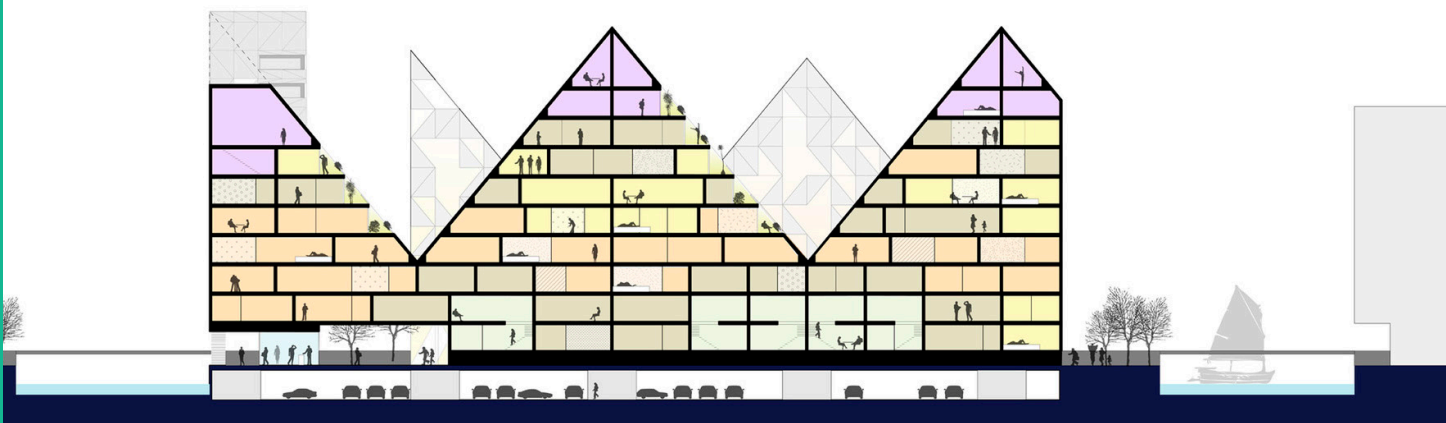

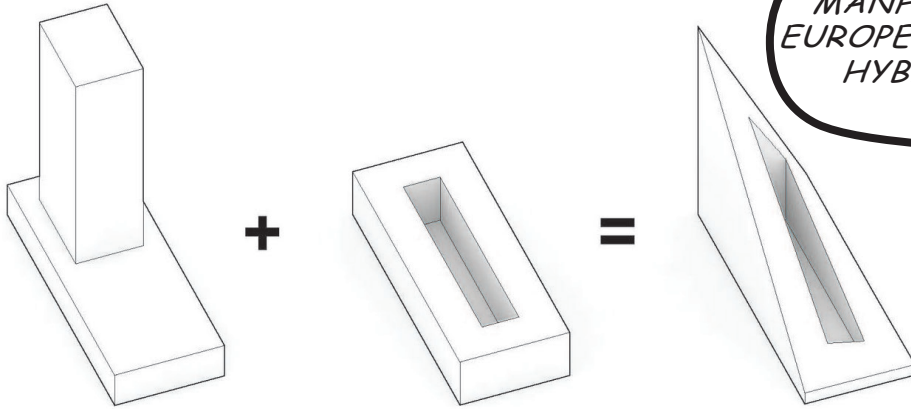

MANHATTAN SKYSCRAPER + EUROPEAN COURTYARD BLOCK = HYBRID COURT-SCRAPER



... THE INTEGRATION OF A EUROPEAN PERIMETER BLOCK AND MANHATTAN HIGH - RISE COMBINES THE ADVANTAGES OF BOTH, THE COMPACT SECURITY OF THE COURTYARD AND THE AIRY VIEWS OF THE SKYSCRAPER ...

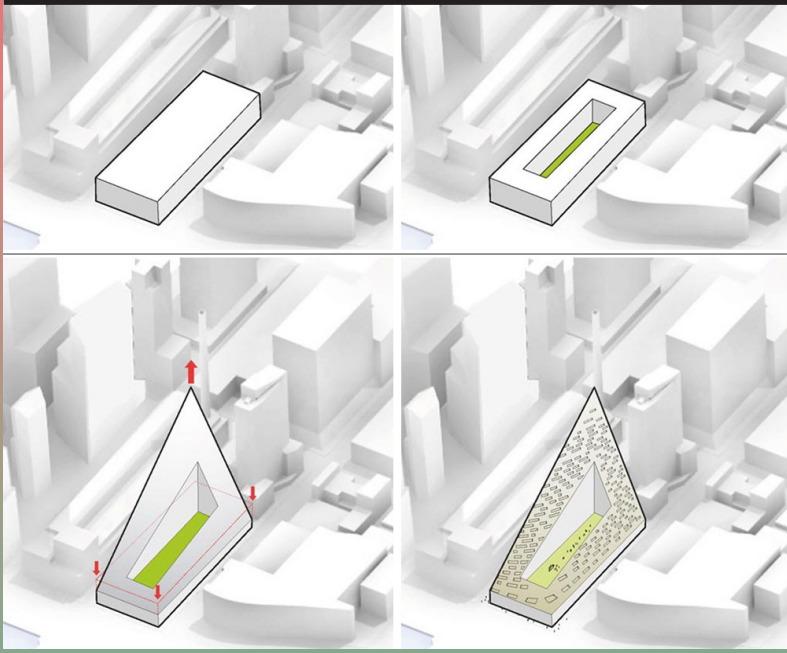

... BJARKE INGELS' FIRST NY PROJECT W57 RE-INTERPRETS THE CONVENTIONAL MANHATTAN BLOCK TYPOLOGY, THE SLOPING FACADE WILL PROVIDE VIEWS FOR ALL 750 RESIDENTS, THE BUILDING FORM BRIDGES ADJACENT LOW RISE AND HIGH RISE BUILDINGS ...



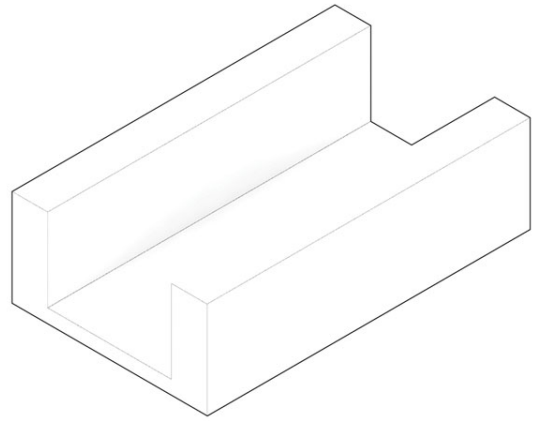
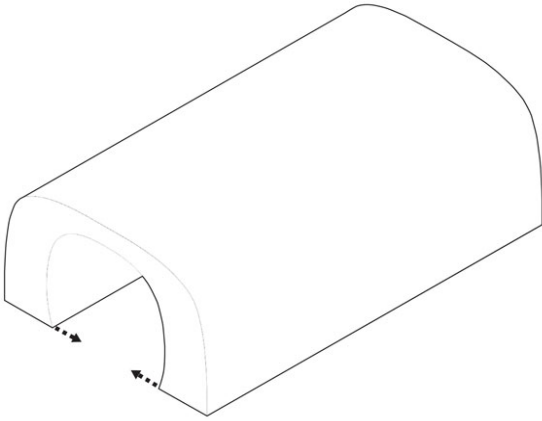

MVRDV'S MARKTHAL IN ROTTERDAM RE-DEFINES THE PUBLIC PRIVATE INTERFACE IN MIXED USE RESIDENTIAL DEVELOPMENT. BY FLIPPING THE RESIDENTIAL TOWER/PLAZA TYPOLOGY, THE BUILDING FORMS AN ARCH OF APARTMENTS ENCLOSING A PUBLIC MARKET HALL.

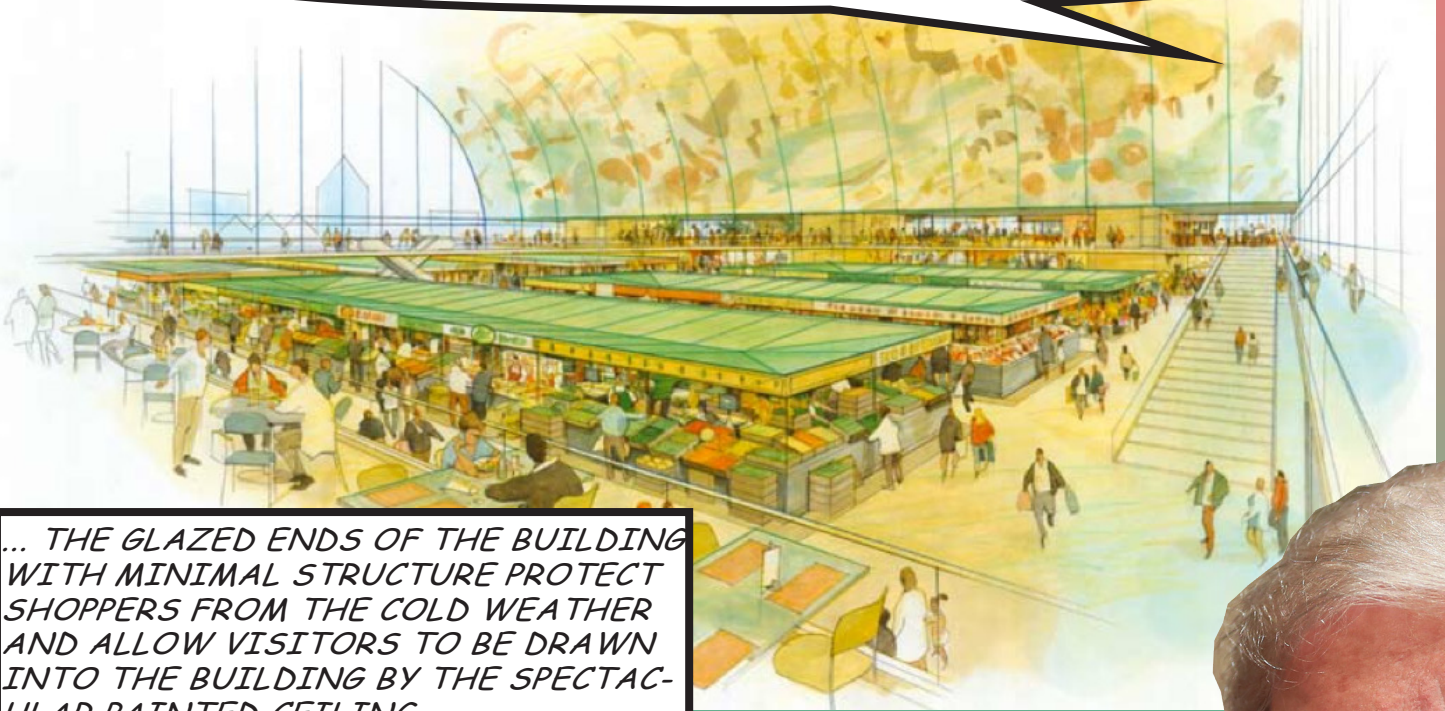

... THE GLAZED ENDS OF THE BUILDING WITH MINIMAL STRUCTURE PROTECT SHOPPERS FROM THE COLD WEATHER AND ALLOW VISITORS TO BE DRAWN INTO THE BUILDING BY THE SPECTACULAR PAINTED CEILING ...





ONE SANTA FE TAKES THE L.A. APARTMENT BLOCK TYPOLOGY AND STRETCHES IT TO A MONUMENTAL SCALE, ARCHITECT MICHAEL MALTZAN EXPLORES DIFFERENT ARRANGEMENTS OF PUBLIC, PRIVATE AND COMMERCIAL PROGRAMS ALONG THE QUARTER MILE LONG BUILDING FOR VARIED SPATIAL QUALITIES.



... AND THEN DONALD TRAVELLED THE WORLD ON HIS PRIVATE JET, AND WHEN HE SAW THE ARCHITECTS' SCHEMES BUILT, DONALD WAS TRUMPED. THE PLANS HAD BEEN REALIZED AND WERE DELIVERING TO VARYING EXTENTS ON THEIR UTOPIAN PROMISES ...



PRAGMATIC UTOPIANISM ALLOWS THE ARCHITECT TO WORK CONCURRENTLY WITH THE BIGGEST PROBLEMS AND THE BIGGEST POTENTIAL IN A PROJECT.



... THROUGH QUESTIONING CONVENTIONAL APPLICATION OF ARCHITECTURAL TYPOLOGY, SIMPLE AND ESSENTIAL CONCEPTS CAN CREATE NEW AND DIFFERENT FORMS OF INTERACTION IN RESIDENTIAL DEVELOPMENT ...



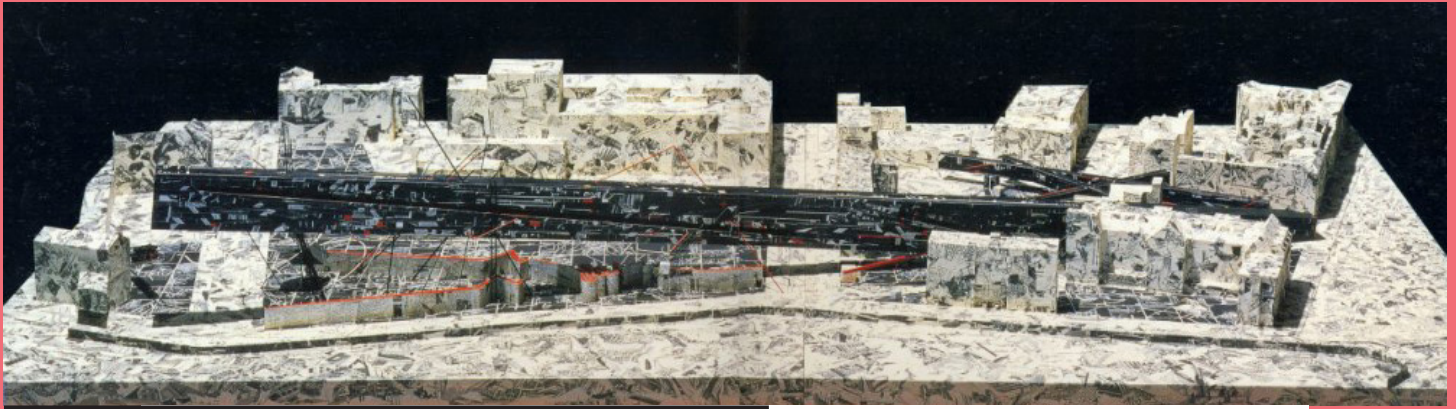

... DANIEL LIBESKIND'S VISIONARY CITY EDGE EVOKES A DIALOGUE WITH THE BERLIN WALL, SUGGESTING A NEW RELATIONSHIP BETWEEN RESIDENTIAL ARCHITECTURE AND THE URBAN CONTEXT ...

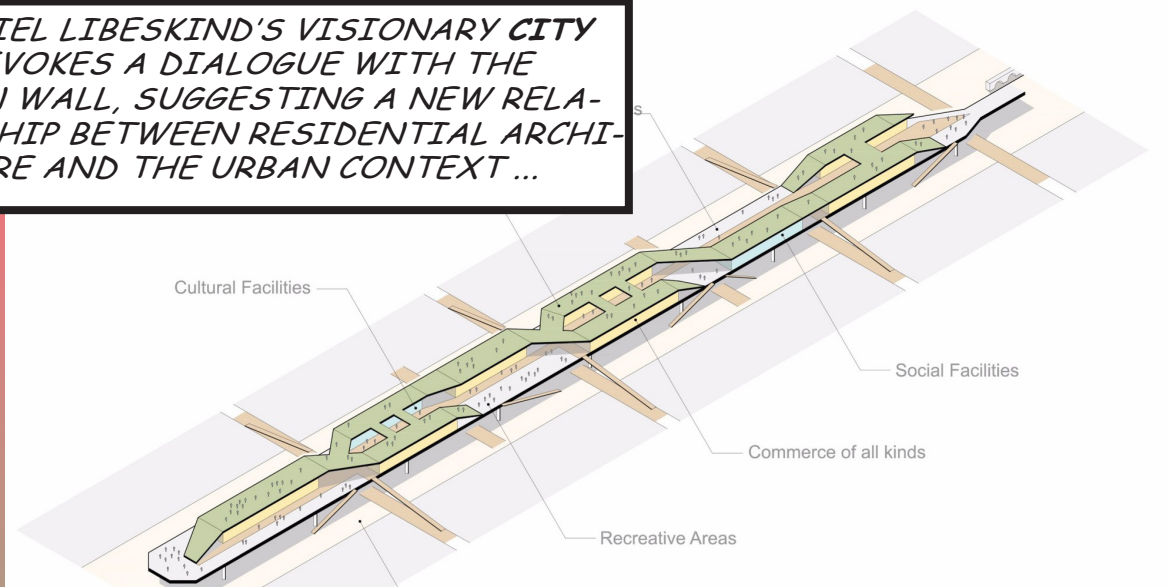

... CHAPULTEPEC PARK IS A COMMERCIAL DEVELOPMENT PLANNED FOR MEXICO CITY, BY EXAMINING THE BUILDING IN SECTION, A VARIETY OF SPACES FOR INTERACTION BETWEEN COMMERCE, PUBLIC SPACE, AND TRANSPORT ARE PRESENTED ...

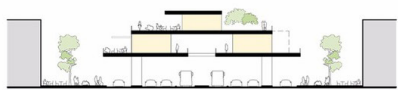

Sec. 7

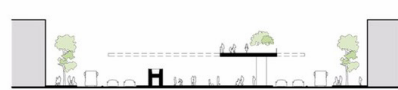

Sec. 8

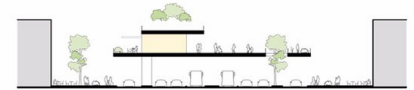

Sec. 9

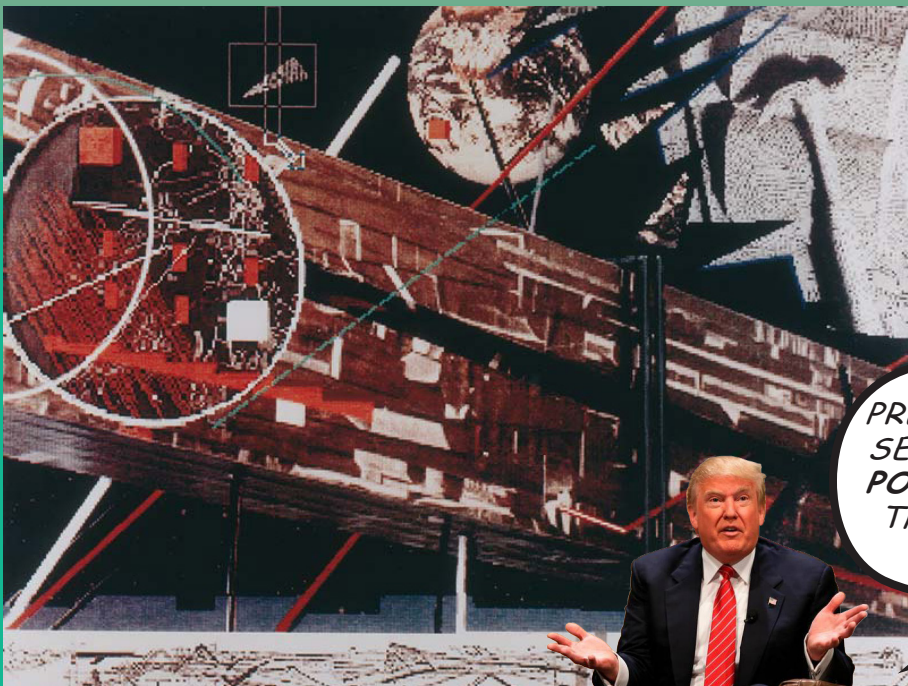

PRECEDENT STUDIES HAVE PRESENTED AN ABSTRACT IDEA OF POROSITY AND PERMEABILITY, THIS COULD BE EXPANDED ON USING ...

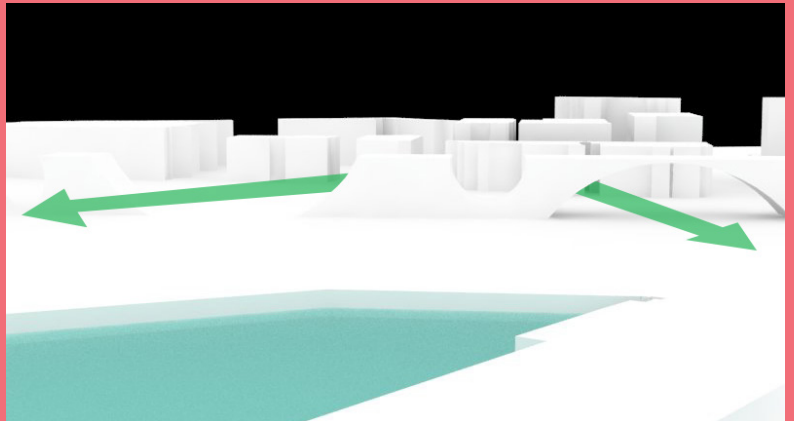
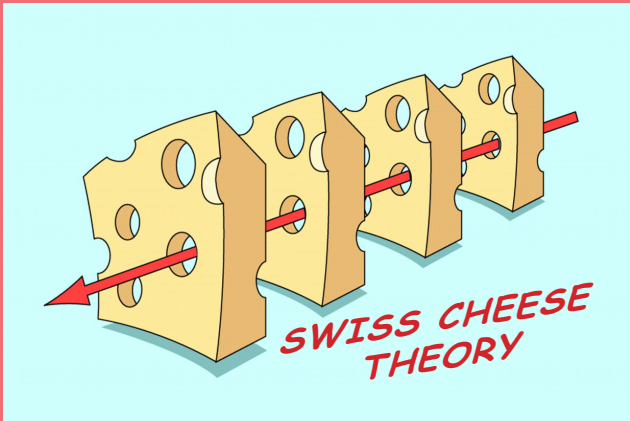

... SWISS CHEESE THEORY ANALYSES THE EFFECTIVENESS OF MAN-MADE SYSTEMS, IF INHERENT QUALITIES OF A BUILDING ARE DESIGNED TO ALIGN WITH MOMENTS OF OPENNESS IN THE CITY, CAN THEY ENCOURAGE MOVEMENT THROUGH THE BUILDING ??...

EMMENTAL BUILDING

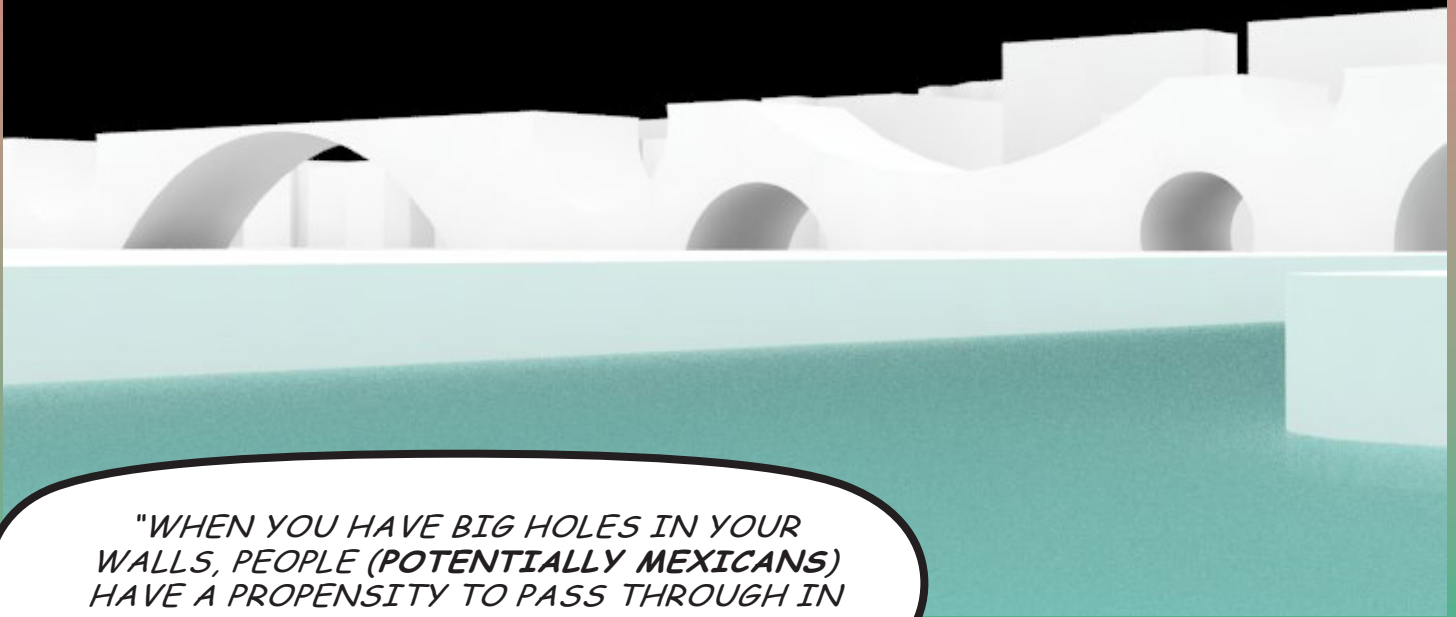

"WHEN YOU HAVE BIG HOLES IN YOUR WALLS, PEOPLE (POTENTIALLY MEXICANS) HAVE A PROPENSITY TO PASS THROUGH IN EVER INCREASING NUMBERS!"



OCCAM'S RAZOR

... THE RELATIONSHIP BETWEEN THE BUILDING SITE AND QUAY STREET SUGGESTS A DIRECTIONALITY FOR THE BUILDING PLAN TO FOLLOW ...

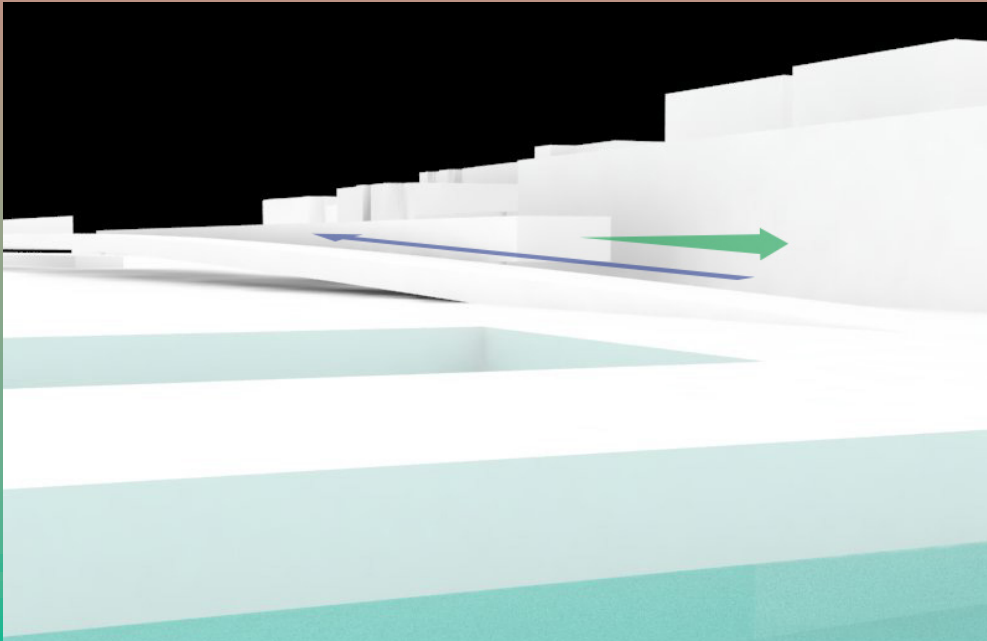

... THIS CONDITION CAN BE CHALLENGED BY ASSERTING ALTERNATE AXES OF TRAVEL THROUGH THE BUILDING, FORMAL CUES CAN INFLUENCE MOVEMENT AND CAN BE USED TO FRAME VIEWS, ASSIGNING VALUE TO CHOSEN FEATURES OF THE ENVIRONMENT ...

TUNNEL VISION

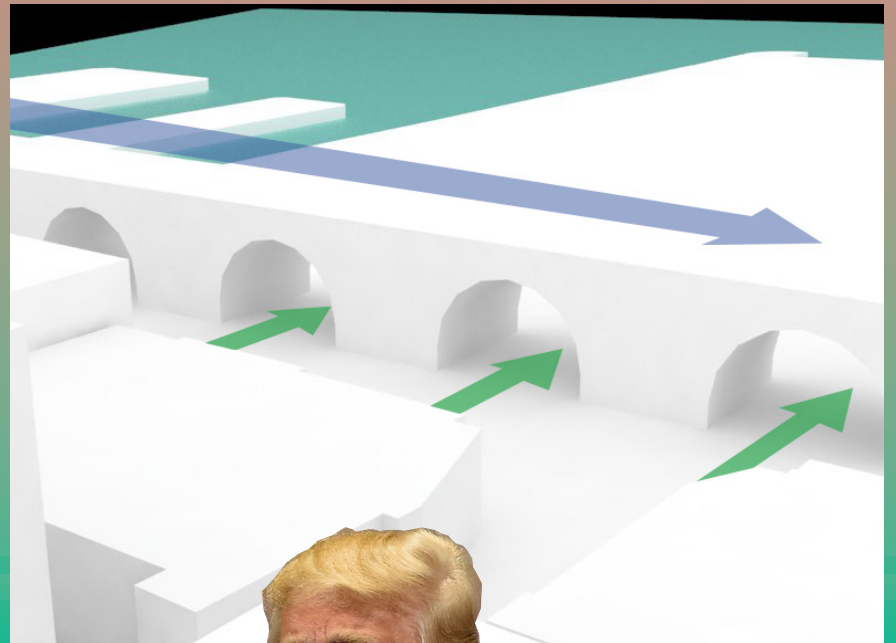

*DONALD TRUMP FOR
NZ PRIME MINISTER !!!*

